

AIR-X
On Line Oil Aeration Monitoring

ONLINE aeration
monitoring

AIR-X

Technical Brochure

ON-LINE LUBRICANT AERATION MEASUREMENT ON RUNNING ENGINES

JANUARY 2010

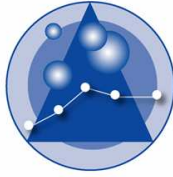

Introduction : The oil aeration problem

The presence of air in the fluid of a working hydraulic system can cause significant performance problems. Mixed air may be in an entrained or dissolved state and it can directly affect such fluid parameters as density, bulk modulus, sonic velocity, etc.

Consequences can be the following :

- Loss of lubricity
- Higher oil temperatures
- Wasted horsepower
- Cavitation problems
- Noisy operation
- Etc.



How does it work?

Air-X is a new instrument designed for on-line monitoring of oil aeration in a running mechanical system (engine, gear box, etc.). The operating principle is based on an accurate density measurement using X-ray transmission. An oil sample coming from the mechanical system is circulated continuously into a compact measuring chamber where the density measurement is performed.

The specific chamber design of Air-X allows the instrument to perform on-line measurements using a very low activity X-ray source. The chamber is self-shielded so that no radiation at all comes out from the unit whatever the operating conditions.

The total volume of oil sampled in "Air-X" is less than 0,5 liter for a minimal impact on the operating mechanical system.

The chamber includes probes that are used for automatic temperature and pressure compensation. Therefore, the air content can be computed and displayed at standard conditions (i.e. $T = 20^{\circ}\text{C}$ and $P = 1 \text{ bar}$).

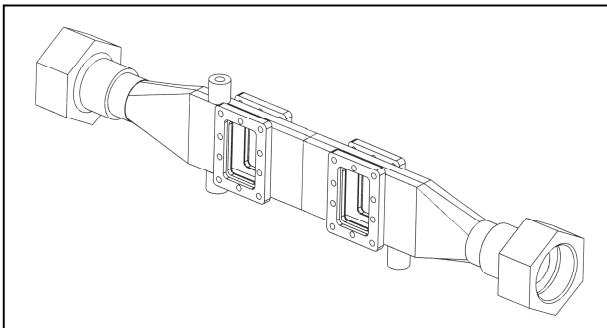

The core of Air-X is a compact measuring chamber with 2 windows: one is used for X-ray transmission measurement, the other for visualisation of the oil flow via a video system.

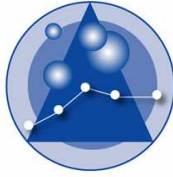

Where to install the equipment ?

Air-X is able to sample and evaluate oil from atmospheric or pressurized lines in an operating hydraulic system. For fired engines, the oil is typically sampled from the sump at a location which is close to the input of the oil pump. The sampling unit of Air-X includes an internal oil pump with accurate and variable flow control. All operating parameters are selected from the user's interface (a PC).

For applications on fired engines oil can also be sampled directly from the gallery. The sampling unit includes a precision valve that limits the pressure drop in the gallery to an acceptable value.

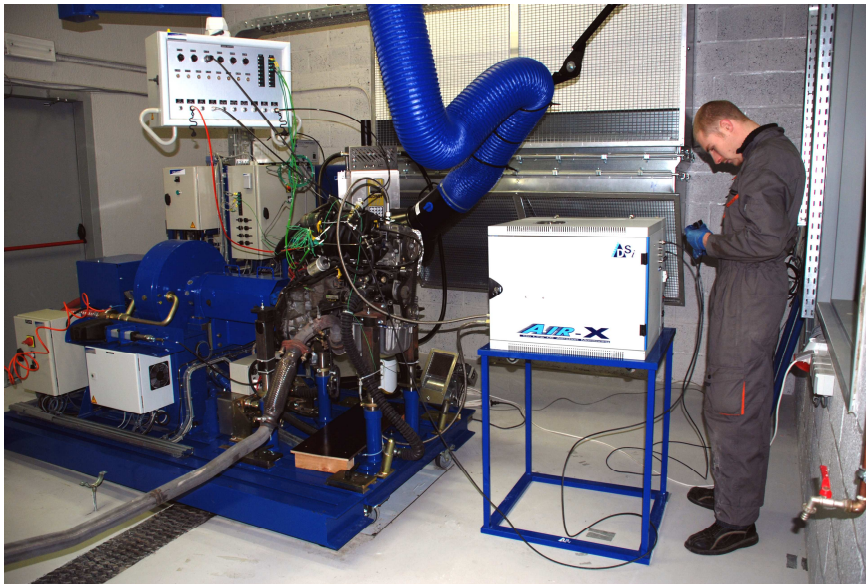

View on the sampling unit of Air-X installed in a test cell

Air-X equipment includes 2 subsystems:

- The sampling unit, a rectangular box to be installed in the vicinity of the running hydraulic system. It contains the measuring chamber with its X-ray transmission system, an hydraulic pump with its controller, and the temperature and pressure measuring probes;
- The data acquisition system (a PC), which is installed remotely, in a control room.

The two units are linked via a single USB cable.

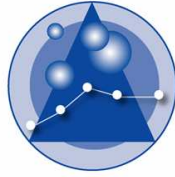

Software

A software package is supplied with Air-X, that offers the following functions :

- Setting-up of equipment
- Calibration
- On-line measurement and automatic data storage
- On-line visualization of the oil flow in the measuring chamber (compressed video signal)

Calibration:

- As the operating principle of Air-X is based on a density measurement it is necessary to identify the law that describes density variations according to temperature. This is easily done using a calibration routine included in the software package. Such calibration must be done once for each type of oil to be used during the tests.
- Then, before starting a new measurement, a single calibration point is done by launching the acquisition while the air content is 0% (engine stopped).

On-line measurement:

The oil is sampled continuously in the measuring chamber but the dwell time for data acquisition can be selected between 1s up to several mins. Short dwell times allow visualizing aeration during transient operating phases of the engine, while longer dwell times provides a high accuracy on the absolute air content.

All measurement data (oil temperature, oil pressure and aeration level) are recorded and can be visualized on a graphic during operation of Air-X. A dedicated routine is also provided, which allows converting the results to a .csv format.

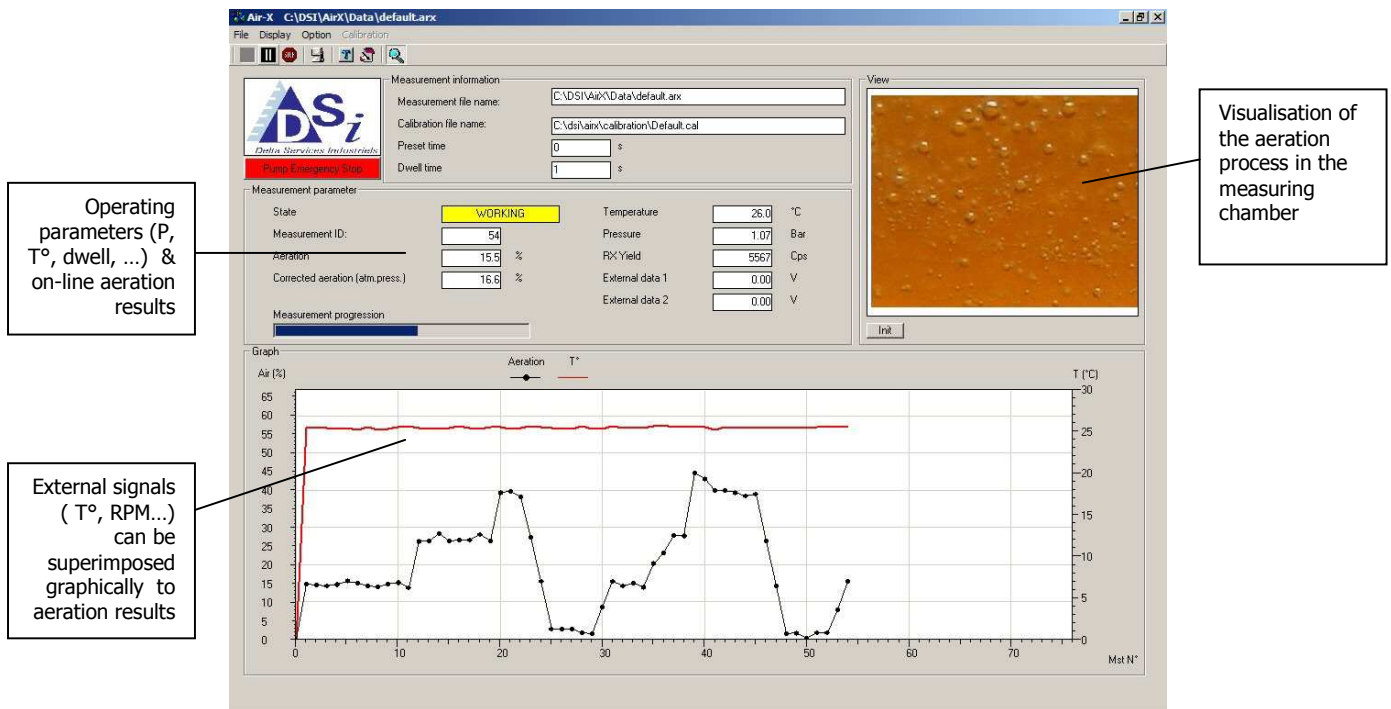

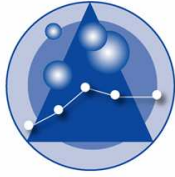

Not a Black Box !

All calibration and measurement parameters can be selected by the user. Moreover, the flow of oil circulating in the measuring chamber can be directly visualized on the PC screen through compressed video signal. This allows the operator to get a better feeling and understanding of the aeration process, which is also an appreciable information. Pictures can be taken at any moment during acquisition, and saved on hard disk.



Standard Air-X system for passenger car engines



*Special configuration for tilt test beds:
The hydraulic unit (right hand box) is separated from
the control unit for more compactness*

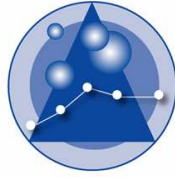

Technical Specifications

“Air-X 1” : standard equipment dedicated to wet sump engines (small to HD engines)

“Air-X 1” is designed to sample continuously the oil from the engine sump (at $P \sim P_{atm.}$) or from the gallery (pressure up to 10 bars). The oil sample is sent to a compact measuring chamber where oil aeration is monitored. Local pressure in the chamber can be varied during the measurement in order to estimate both the entrained (bubbles) and the dissolved gaz fractions.

Dimensions and Weight:

- Measurement unit (cart on 5 wheels, to be installed in the test cell):
 - 600 (Width) x 500 (Height) x 400 (Depth)
 - Weight : ~40 kg
- Remote acquisition unit:
 - Laptop PC (up-to-date model) with 15" TFT screen
 - Windows + “Air-X” software for on-line measurement and data analysis.

Performances:

- Measuring range: 0% to 100% air
- Total sampled oil volume : < 0,5 liter
- Acquisition time: programmable from 1s up to hours
- Operating T° range : -10°C to 160°C
- Pressure range: up to 10 bars
- Oil flow in the measuring chamber:
 - variable from 0.5 to 5 litres/min. with internal pump
 - controlled remotely from Air-X software
- Hydraulic connectors: metric, JIC or BSP (on request)
- Accuracy in terms of aeration results:
 - At 10 s acquisition time : 0,5%
 - At 100 s acquisition time : 0,2%

Power requirements: 110-220VAC/60-50Hz (on demand) - Power consumption < 1kW

Other models are available for applications on dry sump engines and for in-board applications

For more information:

DSi - Delta Services Industriels sprl

3 rue Mont d'Orcq, B-7503 Tournai-Ouest (Froyennes), Belgium

Tel : +32 69 64 06 04 Fax : +32 69 78 00 79

Web site: www.deltabeam.net

e-mail: infos@deltabeam.net

ANS Technologies Inc.
Laboratoire Rene-J-A-Levesque
P.O. Box 6128, Station CV
Montreal (QC) Canada H3C 1J7
Tel: +1-514-343-7669
Fax: +1-514-343-6215
Web site : www.anst.ca
e-mail : info@LPS.UMontreal.ca