

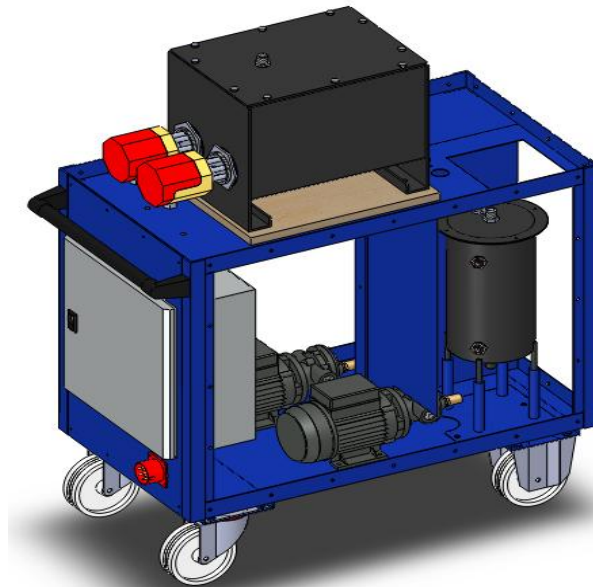

TC-LUBE

EXTERNAL LUBRICATION SYSTEM FOR TURBOCHARGERS



TECHNICAL BROCHURE

INTRODUCTION

Currently, the development of turbochargers (TC) is of particular interest due to the need for low consumption and very low emission diesel and gasoline engines. Downsizing of engines is closely associated with the development of new components that must handle increasing exhaust gas temperatures, leading to the use of advanced materials and technologies for the design of TC bearings.

TC-Lube is lubrication unit especially dedicated to the development and testing of turbochargers. It includes programmable temperature and pressure regulation systems.

TC-Lube allows the lubrication of the TC *independently* from the gallery of the engine. It can also be coupled with on-line wear monitoring equipment or on-line oil consumption monitoring equipment based on the use of radiotracers.

The new equipment is available for various sizes of engines, from small engines to heavy duty.



OPERATING PRINCIPLE

Oil that lubricates the TC is contained in a tank where a heat exchanger allows the heating of the TC oil up to 180°C. A separated primary circuit prevents TC oil from degrading during heating.

Oil pressure in the TC lubrication circuit (upstream of the TC bearing) is regulated manually or automatically according to an external parameter (e.g. gallery pressure). Oil temperature is selectable between 20°C and 180°C. It can also be automatically regulated according to an external parameter.

The following schematic shows a monitoring tool that samples oil from the tank for monitoring TC wear during tests.

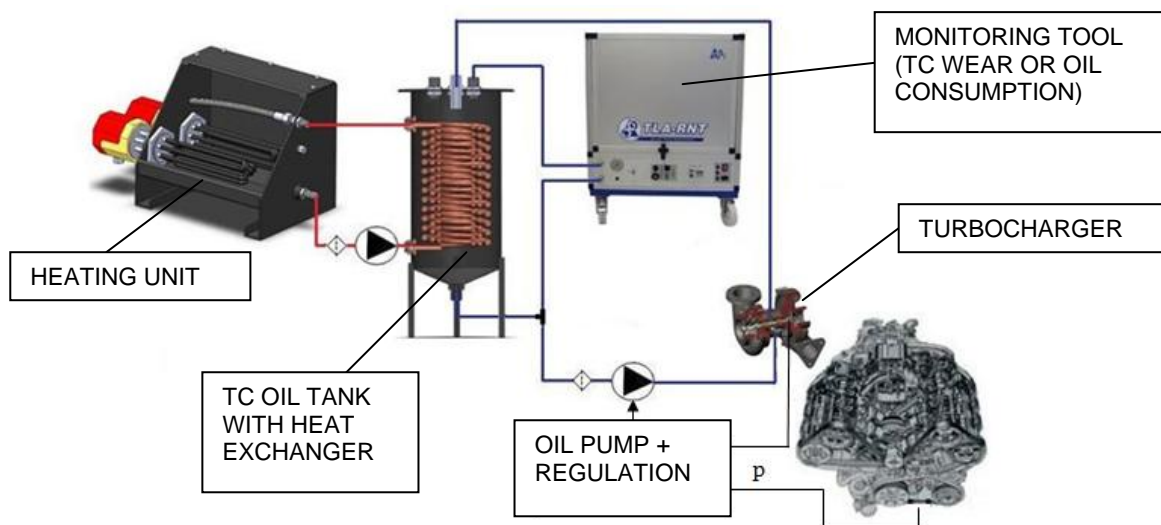

Typical set-up for on-line wear/oil consumption measurement of TC

RANGE OF APPLICATIONS

TC-Lube is convenient for the following purposes:

- **To lubricate a TC independently from the engine.** The TC can be lubricated with different oil formulation from the engine oil, at a different pressure, and/or at a different temperature.
- **To study oil consumption issuing from the TC only.** TC Lube can be coupled to the *C-Lube equipment* for on-line measurement of oil consumption issuing from the compressor stage, from the turbine stage, or from both of them. Various types of lubricants can be used to study the impact of formulation on oil consumption.
- **To study TC bearing wear.** TC Lube can be coupled to the TLA/RNT equipment for on-line monitoring of bearing wear independently from the wear of in the rest of the engine. Thin sand particles or diluted oil can also be added into the TC lubrication circuit to study their impact on bearing wear, without damaging the engine.
- **To investigate lubrication limits.** Combination of TC-Lube and on-line wear measurements make it possible to determine the minimal TC oil pressure needed at various operating conditions, during continuous operation or during specific cycles such as Stop & Start cycles.

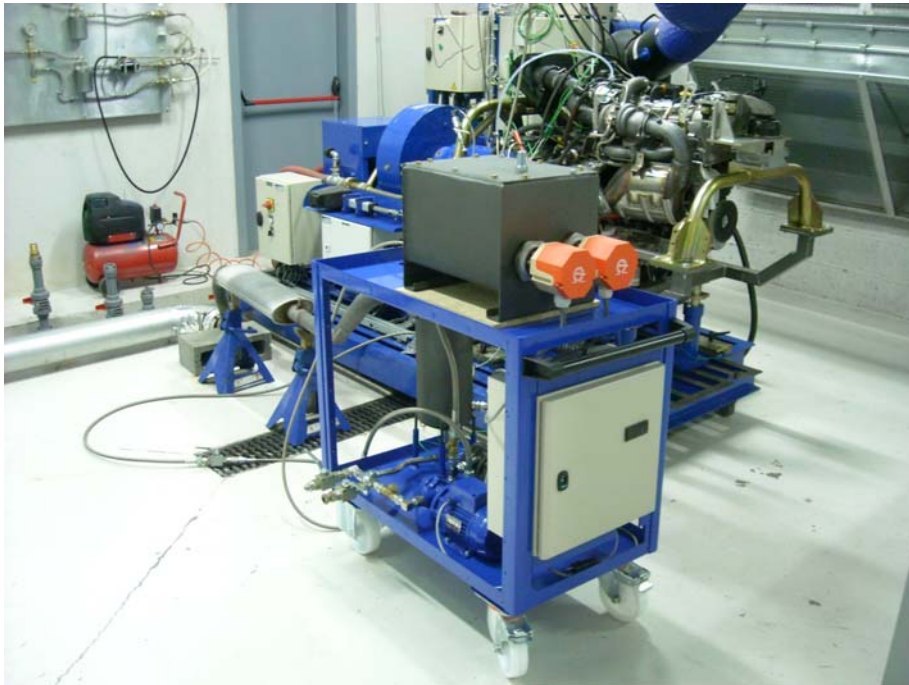

TC Lube equipment installed in a test cell, at DSi facility

For more information:



DSi - Delta Services Industriels SPRL

3 rue Mont d'Orcq
B-7503 Froyennes
BELGIUM
Tel: +32 69 64 06 04
Fax: +32 69 78 00 79

Web site : www.deltabeam.net
e-mail : infos@deltabeam.net

In North America, please contact:

Les technologies
ANS
Technologies

ANS Technologies Inc.
Laboratoire Rene-J-A-Levesque
P.O. Box 6128, Station CV
Montreal (QC) Canada H3C 1J7

Tel: +1-514-343-7669
Fax: +1-514-343-6215
Web site : www.anst.ca
e-mail : info@LPS.UMontreal.ca